

Aluminium Wharf Ladder Flat Type

Model: HXTB-P

Lengths Available in 2m, 2.5m, 3m, 3.5m, 4m, 5m, 6m.

Technical Specifications

Please refer to the next page for wharf ladder's specifications.

Certifications

- **Approval:** ABS test report
- **Inspection Standards:** The safe working load test was performed within the specified inspection scope and witnessed by ABS technical representative. The results were found to be satisfactory according to the supplier's test procedure (No.: HXTB002 Rev: 002). Detailed technical requirements are outlined in the test report.



Manufacturer



Dongtai Martian Ship Equipment Co., Ltd.



MARINE SAFETY ESSENTIALS

We Offer On-Board Firefighting And
Marine Safety Essentials

Disclaimer: Accuracy of all technical data and information are provided to the best knowledge of the manufacturer. Properties, specifications and application parameters are subject to change without notice. The manufacturer does not undertake any liability of any kind whatsoever.

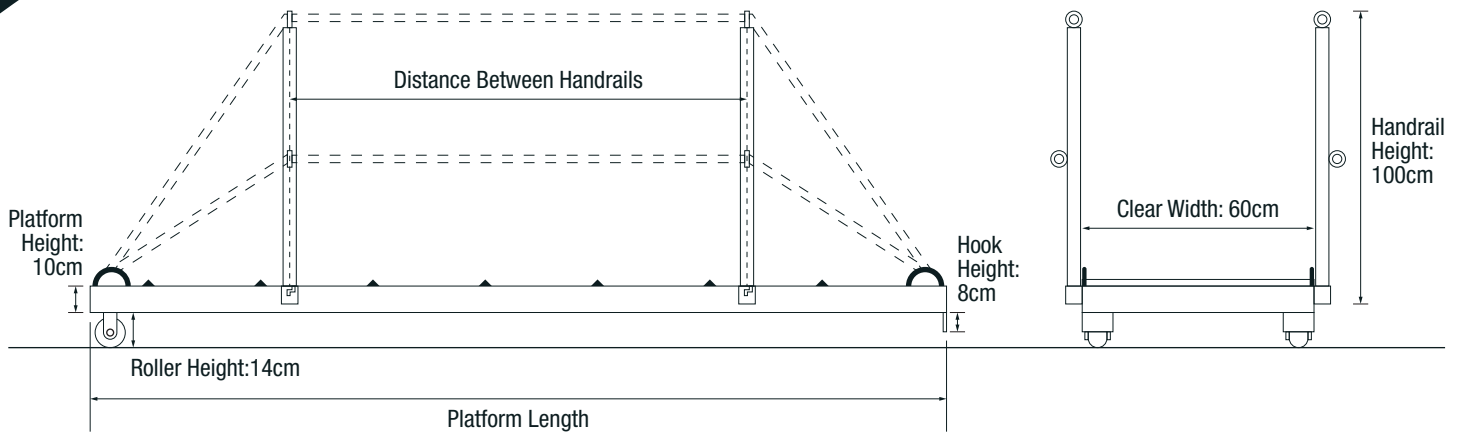

Technical Specifications

Length	Safe Working Load	No. Of Handrails	Distance Between Handrails
2m	143kg	Total: 4pc, 2 on each sides	90cm
2.5m	210kg	Total: 4pc, 2 on each sides	130cm
3m	210kg	Total: 4pc, 2 on each sides	160cm
3.5m	240kg	Total: 6pc, 3 on each sides	105cm
4m	240kg	Total: 6pc, 3 on each sides	131cm
5m	360kg	Total: 8pc, 4 on each sides	120cm
6m	420kg	Total: 8pc, 4 on each sides	153cm

Product Features

- ABS approved safety platform that provides stable and secure access for personnel and cargo when the ship is moored next to a dock.
- Clear width of 60cm allows for safe and easy access for individuals.
- Cross ridges for foot support with non-slip walking surface.
- Designed with rollers and hook for easy mounting.
- The set includes removable aluminium handrails and ropes that can be installed as needed.



MARINE SAFETY ESSENTIALS

We Offer On-Board Firefighting And Marine Safety Essentials

Disclaimer: Accuracy of all technical data and information are provided to the best knowledge of the manufacturer. Properties, specifications and application parameters are subject to change without notice. The manufacturer does not undertake any liability of any kind whatsoever.

Mars Safety International Pte Ltd is the Singapore Overseas Branch of Dongtai Martian Ship Equipment Co., Ltd.

No.1 Tuas Link 1, Singapore 638583 Tel.: +65 6862 1212 Fax: +65 6897 9959 For Orders, please send enquiry to Sales@mars-safety.com